

Pressure control panel BM55-1

spectro lab

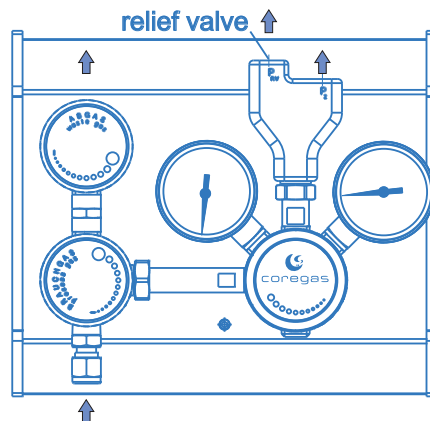

Pressure control panel BM55-1 with valve in the outlet adapter



Product features

- Wall- and cabinet-mounting pressure control panels
- For non-corrosive gases up to quality 6.0
- Laboratory-style design
- Ergonomically designed
- Modular design (to be extended to 2, 3 etc. cylinders)
- Filter at the process gas inlet valve
- Diaphragm-type shut-off valves optimised for low internal volume with On/Off position indicator
- Suitable for ECD-applications
- Diaphragm-type pressure regulator with high control accuracy and anti-vibration device
- Outlet adapter with integrated relief valve and optional diaphragm-shut-off valve (this prevents the outlet piping from draining during disconnecting the panel)
- Designed for easy installation
- Approved for use with oxygen
- Suitable for inlet pressure values up to 300 bar
- Compact design especially for installation into safety cabinets for gas cylinders
- Dual-stage model: BM56-1

Technical data

Type	single-stage
Inlet pressure P_1	max. 300 bar
Outlet pressure P_2	10/20/50/100/200 bar
Materials	
Body regulator and valves:	chrome-plated brass
Valve seat regulator:	PA 11
Valve seat valves:	PVDF
Diaphragm regulator:	Hastelloy C276
Diaphragm valve:	Hastelloy C276
Soft goods:	EPDM, FKM
Filter:	Sintered bronze B60
Inlet connector	SS compression ring fitting 6x1 mm
Temperature range	-30°C to +60°C
Leak rate (to atmosphere) (via seat)	1x10 ⁻⁸ mbar l/s He 1x10 ⁻⁶ mbar l/s He
Pressure gauges	Safety pressure gauges ISO5171/cl 1.6/NG50
Weight	4,5 kg

Flow curves BM55-1

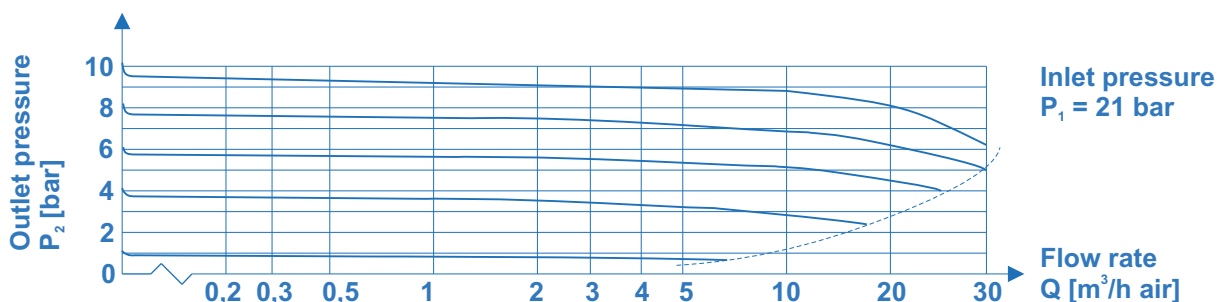

Pressure control panel BM55-1

spectro lab

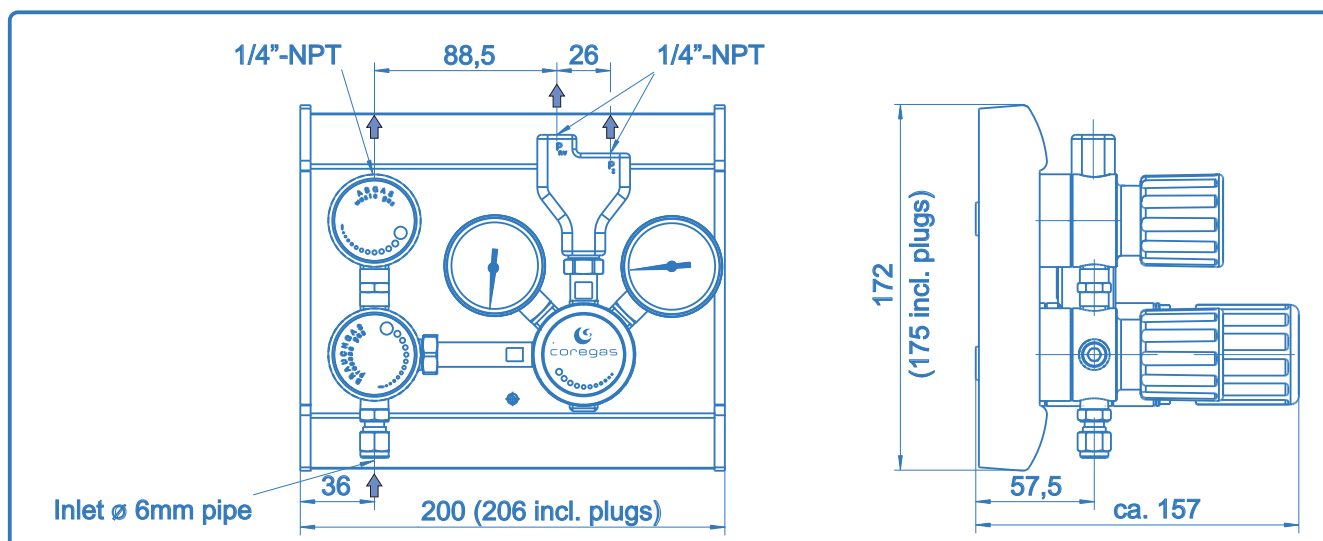

Process gas valve also with 300 bar - pneumatic-actuator upon request!

Ordering information:
Pressure control panels BM55-1

BM55 - 1 - 300 - 10 - M - M - V - N₂

Inlet pressure P₁

100 - max. 100 bar
200 - max. 200 bar
300 - max. 300 bar

Outlet pressure P₂

10 - max. 10 bar
20 - max. 20 bar
50 - max. 50 bar
100 - max. 100 bar
200 - max. 200 bar

Inlet press. indication

M - pressure gauge
K - contact pressure gauge

Gas type

Please specify gas type with your order (selection of valve seat material)

Outlet adapter

0 - without valve
V - valve (manual)
VP - pneumatic-valve

Outlet press. indication

M - pressure gauge
K - contact pressure gauge

Specifications

- SPECTROLAB - components guarantee maximum quality by using high grade materials and a quality assurance program acc. to ISO 9001.
- All components which come into contact with the medium are cleaned in an ultrasonic cleaning system (CFC-free) with the special cleaning process SPECTRO-CLEAN® and are then baked out.
- SPECTROLAB - components undergo a 100% Helium-leak-test.

Pressure indication

- All pressure regulators can be equipped with pressure gauges or contact gauges for in- and outlet pressure indication.

Important note regarding component selection

- In order to assure safe operation it is essential to take the configuration of the whole system into account when selecting a control panel.
- The function of the components, the compatibility of the materials, correlating temperature ranges, correct installation, operation and maintenance in accordance with the relevant regulations are the responsibility of the system designer and the user.